

Linear actuators for operating air control dampers and slide valves in ventilation and air-conditioning systems

- For air control dampers up to approx. 1 m<sup>2</sup>
- Actuating force 150 N
- Nominal voltage AC 100 ... 240 V
- Control: Open-close or 3-point
- Length of stroke up to max. 60, 100, 200 or 300 mm, adjustable in steps of 20 mm

**Overview of types**

Type	Stroke	Weight
LH230A60	Up to max. 60 mm, adjustable in steps of 20 mm	450 g
LH230A100	Up to max. 100 mm, adjustable in steps of 20 mm	495 g
LH230A200	Up to max. 200 mm, adjustable in steps of 20 mm	530 g
LH230A300	Up to max. 300 mm, adjustable in steps of 20 mm	565 g

**Technical data**

<b>Electrical data</b>	Nominal voltage	AC 100 ... 240 V, 50/60 Hz
	Power supply range	AC 85 ... 265 V
	Power consumption	In operation 1.5 W @ nominal force At rest 1 W For wire sizing 5 VA
	Connection	Cable 1 m, 3 x 0.75 mm <sup>2</sup>
<b>Functional data</b>	Actuating force	150 N @ nominal voltage
	Stroke	See «Overview of types»
	Direction of stroke	Reversible with switch 1 ↑ resp. 0 ↓
	Running time	LH230A60 90 s / 60 mm LH230A100/200/300 150 s / 100 mm
	Sound power level	<35 dB (A)
<b>Safety</b>	Protection class	II Totally insulated <input type="checkbox"/>
	Degree of protection	IP54 in any mounting position
	EMC	CE according to 89/336/EEC
	Low voltage directive	CE according to 73/23/EEC
	Mode of operation	Type 1 (to EN 60730-1)
	Rated impulse voltage	4 kV (to EN 60730-1)
	Control pollution degree	3 (to EN 60730-1)
	Ambient temperature range	-30 ... +50 °C
	Non-operating temperature	-40 ... +80 °C
	Ambient humidity range	95% r.H., non-condensating (to EN 60730-1)
Maintenance	Maintenance-free	
<b>Dimensions / Weight</b>	Dimensions	See «Dimensions» on page 3
	Weight	See «Overview of types»

## Safety notes



- The actuator is not allowed to be used outside the specified field of application, especially not in aircraft or any other form of air transport.
- **Caution: Power supply voltage !**
- **Assembly must be carried out by trained personnel. Any legal regulations or regulations issued by authorities must be observed during assembly.**
- The device may only be opened at the manufacturer's site. It does not contain any parts that can be replaced or repaired by the user.
- The rotary supports and coupling pieces available as accessories must always be used if lateral forces are likely.  
In addition, the actuator must not be tightly bolted to the application. It must remain movable via the rotary support (refer to «Assembly notes»).
- If the linear actuator is exposed to severely contaminated atmosphere, appropriate precautions must be taken on the system side. Excessive deposits of dust, soot etc. can prevent the gear rack from being extended and retracted correctly.
- If not installed horizontally, the gear disengagement pushbutton may only be actuated when there is no pressure on the gear rod
- When calculating the required actuating force, the specifications supplied by the damper or slide valve manufacturers (cross section, design, installation site), and the air flow conditions must be observed.
- If a rotary support and/or coupling piece is used, losses in the actuation force are to be expected.
- The device contains electrical and electronic components and is not allowed to be disposed of as household refuse. All locally valid regulations and requirements must be observed.

## Product features

<b>Manual override</b>	Manual operation is possible with the pushbutton (the gearing latch remains disengaged as long as the pushbutton is pressed or detented).
<b>Stroke adjustment</b>	The stroke of the gear rack can be adjusted on both sides in increments of 20 mm by means of mechanical end stops.
<b>High functional reliability</b>	The actuator is overload-proof, requires no limit switches and automatically stops when the end stop is reached.

## Accessories

	Description	Data sheet
<b>Mechanical accessories</b>	Rotary support to compensate lateral forces, type Z-DS1	T2 - Z-LH..A..
	Coupling piece, type Z-KS2	T2 - Z-LH..A..
	Mechanical limiter set, Typ Z-AS2	T2 - Z-LH..A..

## Electrical installation

### Wiring diagrams

#### Notes

- Caution: Power supply voltage !
- Other actuators can be connected in parallel. Please note the performance data!



Direction of stroke



### Open-close control

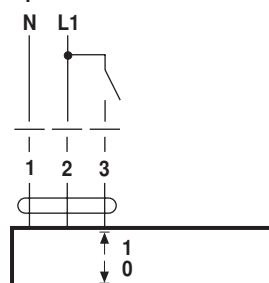

### Connection 3 takes priority

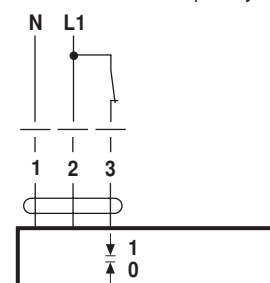

### 3-point control

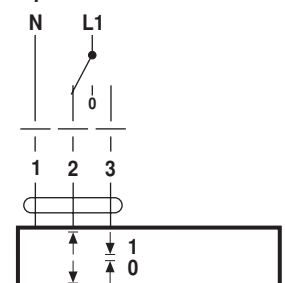

## Dimensions [mm]

## Dimensional drawings

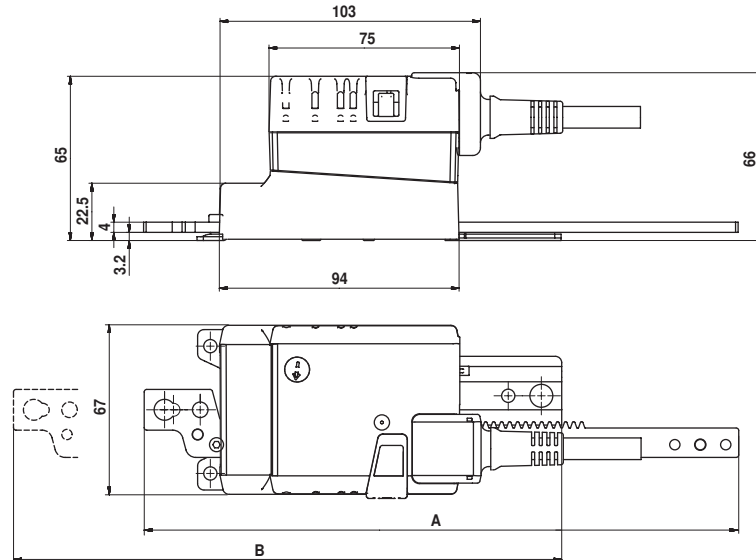

Type	Max. Stroke	A	B
LH230A60	60	193.5	224.2
LH230A100	100	233.5	264.2
LH230A200	200	333.5	364.2
LH230A300	300	433.5	464.2

## Assembly notes

**Application without lateral forces**

The linear actuator is screwed directly to the housing at three points. Afterwards, the head of the gear rod is fastened to the moving part of the ventilation application (e.g. damper or slide valve).

**Application with lateral forces**

The coupling piece with the internal thread (Z-KS2) is connected to the head of the gear rod. The rotary support (Z-DS1) is screwed to the ventilation application.

Afterwards, the linear actuator is screwed to the previously mounted rotary support with the enclosed screw. Afterwards, the coupling piece, which is mounted to the head of the gear rod, is attached to the moving part of the ventilation application (e.g. damper or slide valve).

The transverse forces can be compensated for to a certain limit with the rotary support and/or coupling piece. The maximum permissible swivel angle of the rotary support and coupling piece is  $10^\circ$   laterally and upwards.

**Caution**

If a rotary support and/or coupling piece is used, losses in the actuation force are to be expected.

